

English



ALRAEDY
ENGINEERING COMPANY

ALRAEDY ENGINEERING CO.
For Safety and Fire Fighting Systems



0782 952 2206



0770 318 8329



Iraq - Basra Governorate
Al-Jamhuri Hospital intersection
Near Basra Police Station

www.alraedy.com



ALRAEDY
ENGINEERING COMPANY





Our Vision

Al-Raedy Engineering Company aspires to be the leading and most distinguished company in Iraq in the field of fire protection and firefighting. Our goal is to provide integrated and advanced solutions that meet the needs of the local market while keeping pace with global technological advancements. We strive to be the first choice for anyone seeking safety and protection in both large and small projects, committed to the highest standards of quality and innovation. We aim to solidify our position as a reputable company, distinguished by our ability to execute vital projects that meet the highest safety standards and achieve customer satisfaction.



Our Mission

At Al-Raedy Company, we are committed to delivering comprehensive and integrated fire-fighting solutions aimed at protecting lives and property across various environments. We continuously seek to enhance our services and products by relying on the latest technology and best practices in fire protection. Our mission is to build long-term relationships with our clients by providing high-quality services with a focus on innovation, professionalism, and continuous improvement. Moreover, we are dedicated to developing our human resources to ensure the provision of top-notch services according to the highest safety and quality standards.

الموزع الحصري في جنوب العراق



NAFFCO

PASSION TO PROTECT



نافكو لصناعة معدات وانظمة الحريق

ALL FIRE PROTECTION SOLUTION PRODUCTS



شركة الراعي الهندسية

AL-RAEDY ENGINEERING COMPANY



NAFFCO
PASSION TO PROTECT

الموزع الحصري لشركة نافكو في العراق

30 سنة
من الخبرة

العراق - بصرا القادح - مستشار الجمهوري
TRADING, SAFETY & FIREFIGHTING EQUIPMENT

info@alraedy.com
www.alraedy.com

مماراة الكفيل بوزارة التجارة والسلامة ومطابقة العراق
07726143999-07801001910

Table of content

Organization review	6
Range of systems	7
Company we present	11
Certificates	12
Products	25
Our projects	48

ORGANIZATION REVIEW



Registered Office Address

General contracting, civil engineering, fire-fighting equipment, equipping and installing in all types of buildings and oil fields, and others.



Years Of Experience

Civil Engineering: 20 years
Safety and firefighting: 17 years



Registered Office Address

Al-Raedy Engineering Company
Basrah St. , Basra, Iraq



Phones

Iraq – Tel : +964 780 100 1910
Iraq – Tel : +964 782 952 2206
Dubai – Tel : +971 50 480 7115



E-mails

info@alraedy.com
akinhar@yahoo.com
altayyeb@alraedy.com

RANGE OF SYSTEMS



Fire Fighting Systems

Dry & Wet Standpipe	Sprinkler
Deluge	Pre-Action
Foam	FM-200 Clean Agent
Carbon Dioxide	Pro-Inert
Micro Mist	VESDA
Wet Chemical	Suppression Gas Detection

Warning Systems

Fire Alarm (Addressable & Conventional)	Emergency Lighting
Voice Evacuation	CCTV & Surveillance
Access Control	Video Smoke Image Detection
Intruder Alarm	Public Address

Fire Fighting Pump (End Suction Centrifugal, Horizontal Split Case, Vertical Turbine, Vertical Multi-Stage Centrifugal Jockey Pump and Regenerative Turbine Jockey Pump)

Products

Fire Extinguishers (CO2, Dry Powder, Foam, Water, Wet Chemical and HFC-236)	Cabinets & Hose Reels
(Fire Hydrants (all types	Valves (all type)
Pipe & Fittings	Rescue Devices
(PPE (Personal Protective Equipment	Fire Doors
Fire Trucks, Ambulances, Rescue & Platform Vehicles	



Staff

The company depends on managing and undertaking its projects on a diverse team that contains long experience and top academic certificates that qualifies it to successfully complete its projects with international engineering standards. Not only that, but the company insisted on training and developing its staff through courses and workshops within specialized academies.

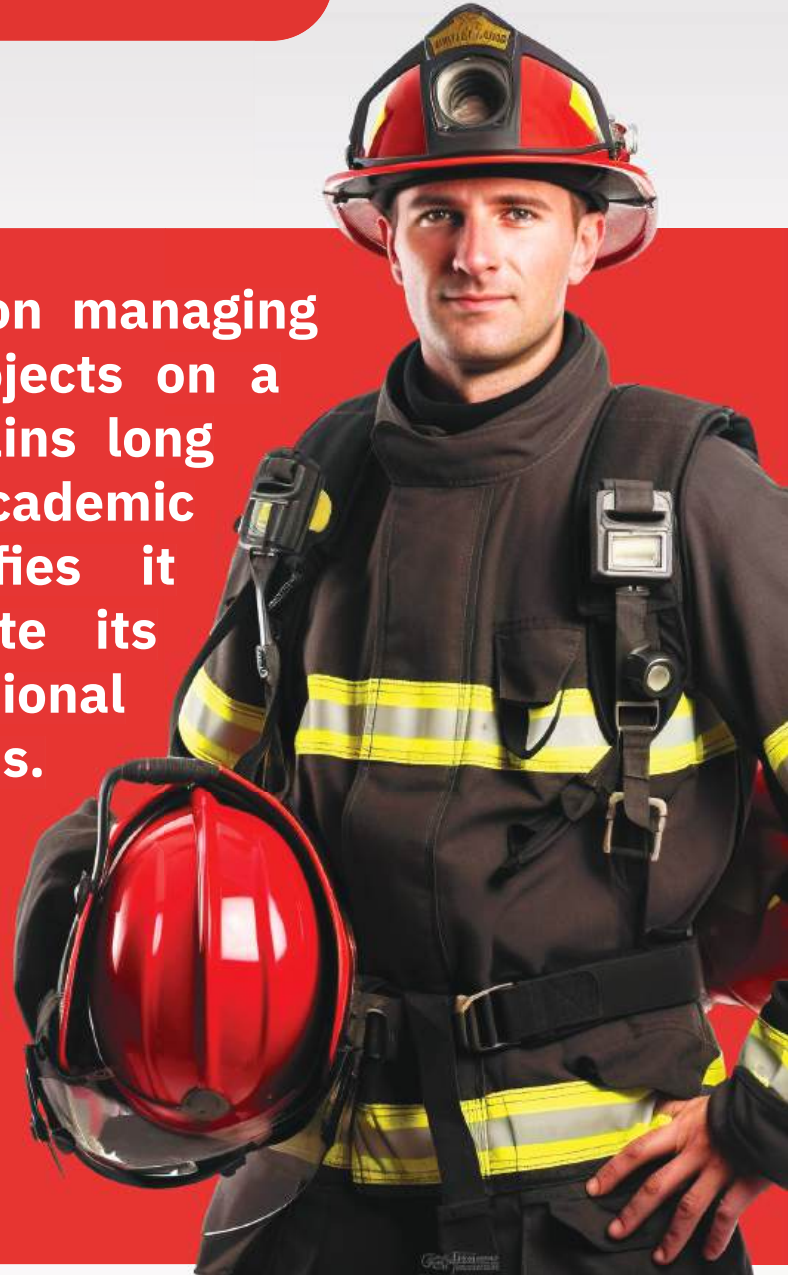



**OUR PASSION
IS TO PROTECT AND SAVE YOUR LIFE**

No.	Specialization	#
1	Project manager	1
2	Excutive manger	2
3	Mechanical engineer	1
4	civil engineer	1
5	Electrical engineer	2
6	Safety engineer	4
7	IT engineer	2
8	Mechanical technician	3
9	Electrical technician	5
10	Accountant	2
11	Lawyer	1
12	Worker	10

In iraq we present



(National Fire Fighting Manufacturing Co. (NAFFCO))

NAFFCO is the first firefighting manufacturing company in all of United Arab Emirates. NAFFCO have huge manufacturing plant in the Jebel Ali Free Zone where they manufacture a huge range of products. NAFFCO is an ISO 9001 certified company through BVQI, LPCB and UL.

The Approvals

NAFFCO manufactures all its items according to the latest international standards. Fire Extinguisher are made in accordance with BS EN 3 and approved by KITEMARK and SABS. They also conform to NFPA (National Fire Protection Association) and Civil Defense requirements.

NAFFCO is also a member of NFPA, National Safety Council, Fire Extinguisher Trades Association and British Standards Institution.





نافگو

FIRE, SAFETY
& SECURITY



CERTIFICATES OF APPROVAL

CERTIFICATES



CERTIFICATES OF APPROVAL

1. Certificate submitted by NAFFCO approved that ALRAEDY ENGINEERING CO. is the Official Distributor of NAFFCO in IRAQ.
2. Certificate of appreciation submitted by NAFFCO to ALRAEDY ENGINEERING CO. approved our outstanding Contribution and Excellent Sales Performance in 2014-2015.
3. Certificate of appreciation submitted by NAFFCO to ALRAEDY ENGINEERING CO. as the Excellent Support and Cooperation to the Fire Fighting Industry for 2016 -2017.
4. Certificate submitted by Basra Director of Civil Defiance to approve that Mr. SAEED KADHIM has Practical and scientific experience to do the following:
 - Design, installation, and commissioning, and repairing all types of fire alarm system
 - Fire investigation, fire lose and causes, and fire preventions
 - Training of fire brigades fireman and safety groups with all equipment's
 - Repair and maintenance all the firefighting equipment's.

CERTIFICATES



- 5.** OSHA certificate approved that Dr. ALTAYYEB ABDULLAH accomplished training course in Occupational Safety and Health Standards for Construction Industry.
- 6.** Certificate submitted by NAFFCO to approve that Dr. ALTAYYEB ABDUULAH and Mr. WALLED ABDULLAH had accomplished training for Operation Fire Pump Systems.
- 7.** Certificate of appreciation submitted by DIGINETS MANAGEMENT SERVICES approved that Mr. WALLED ABDULLAH accomplished Sales Master Class Workshop.
- 8.** Certificate of appreciation submitted by HOJV BASRA WATER SUPPLY IMPROVEMENT PROJECT to ALRAEDY ENGINEERING CO. approved our outstanding performance and the great effort to support HOJV safety department at Basra Water Supply Improvement Project.

CERTIFICATES



DISTRIBUTION AUTHORIZATION LETTER

We, National Fire Fighting Manufacturing FZCO, Dubai- United Arab Emirates, manufacturer of firefighting products, systems and equipment under "NAFFCO" brand name, hereby authorize.

M/s Al Raedy Engineering Co.
Basrah- Iraq
MOB +964 780 100 1910
Eng. Abdullah Kinhar (Managing Director)

As one of our distributors in South of Iraq to market and supply all Fire Fighting equipment manufactured and supplied by National Fire Fighting Manufacturing FZCO under the brand name "NAFFCO" in Basra.

This authorization shall take effect from 1st January 2023 up to 31st December 2024, and to be renewed by mutual consent in writing from both parties, for another two years, at the expiration of this authorization.

نحن الشركة الوطنية لصناعة معدات مكافحة الحريق ش.م.ح
لدى - الإمارات العربية المتحدة، مصنعين لأنظمة الإطفاء
ومكافحة الحريق، تحت العلامة التجارية NAFFCO، قد
فوضنا

شركة الراعي الهندسية

البصرة - العراق

موبايل +9647801001910

المهندس /عبدالله كنهان(مدير عام)

كأحد الموزعين المعتمدين لدينا في جنوب العراق لترويج وبيع

منتجاتنا، والمصنعة من قبلنا "الشركة الوطنية لصناعة معدات

مكافحة الحريق ش.م.ح" تحت العلامة التجارية NAFFCO.

يعتبر هذا التحويل صالحا للعمل فيه إعتبارا من
تاريخ 2023/1/1 حتى 2024 /12/31، على أن يتجدد عند
إنتهاء صلاحية هذا التفويض لمدة سنتين إضافيتين بموافقة
الطرفين خطيا.

For National Fire Fighting Manufacturing FZCO

Samer Hennawi



الشركة الوطنية لصناعة معدات مكافحة الحريق ش.م.ح
National Fire Fighting Manufacturing FZCO
PO Box 170114, Dubai, United Arab Emirates. Tel.: +971 4 815 1111, Fax: +971 4 815 1222, E-mail: info@naffco.com, www.naffco.com
شركة ذات مسؤولية محدودة، تأسست بموجب القانون رقم 2 لسنة 1991 ويضاً 30 لسنة 1992 رقم 1 لسنة 1998
مفوض بموجب 31 من 2 من 1946 و implementing regulation no 1 of 1999 with limited liability



CERTIFICATES



CERTIFICATES



CERTIFICATES



Certificate of Achievement

This is to certify that

Altayyeb Abdullah Kadhim

*Diligently and with merit satisfied the examiners and completed
an OSHA 30 Hour training course in
Occupational safety and health Standards for General Industry*

*Based on material distributed by the United States Department of Labor, Occupational Safety
and Health Administration regarding compliance requirements as set forth in 29 CFR 1910.*

*Training was conducted at NACA for Engineering services & Trading - NEST,
Al Watan St., Al-Rashed Hotel, Basra, IRAQ*

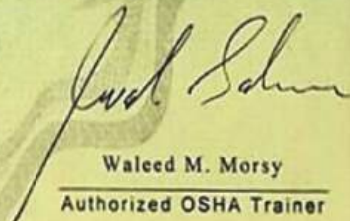

Waleed M. Morsy
Authorized OSHA Trainer

Course End Date : 26 Jul 2015

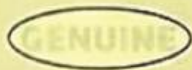

Master log certificate GI 1725 1
OSHA compliance card ID 30-0002647



CERTIFICATES



CERTIFICATES



CERTIFICATES



Federation of Trade Unions in Basra

اتحاد نقابات عمال البصرة
نقابة عمال الخدمات الاجتماعية والسياحية

رقم الشهادة: ٧٨
تاريخ الإصدار: ٢٠١٩/٤/٨
تاريخ النفاذ: ٢٠٢٠/٤/٨

شهادة ممارسة المهنة

استنادا الى احكام المادة (٢٨) من قانون التنظيم النقابي رقم (٥٢) لسنة ١٩٨٧ والفقرة (٢) من المادة (٤٠) الداخلي الموحد للمنظمات النقابية في العراق والتعليمات الصادرة من الاتحاد العام لنقابات العمال في العراق نؤيد بأن السيد (**عبد الله كاظم كنهان**) يمارس مهنة (**ادارة شركة الزاندي الهندسية للسلامة العامة**) منذ عام (**٢٠١٩**) ولاخلاصة في العمل ومساهمته الجليلة في تعزيز وتنمية قدراته المهنية وتطويرها زود بهذه الشهادة لعام (**٢٠١٩**).

According to the provisions of Article 28 of the Trade Union Regulatory Act No. 52 of 1987 and paragraph (2) of Article (40) of the common rules of procedure of trade union organizations in Iraq and the instructions issued by the General Federation of Trade Unions in Iraq.

We support that Mr. (**Abdullah Kazem Kanhar**) practicing (**Management Company**) since (**2019**) and private work and its contribution to the venerable in the promotion and development of professional abilities and development provided this certificate for the year (**2019**).

نافذه لمدة عام من تاريخ الاصدار رئيس النقابة



HITACHI Inspire the Next

OTV VEOVIA

HOJV BASRA WATER SUPPLY IMPROVEMENT PROJECT
HOJV SAFETY DEPARTMENT

Certificate of Appreciation
ISSUED TO

ALRAEDY ENGINEERING CO. شركة الزاندي الهندسية

Your out standing performance and the great effort to support HOJV safety department at Basra Water Supply Improvement Project
is a Greatly Appreciated

Eng. AHMED TAWFIK
HOJV Safety Department



CERTIFICATES



CERTIFICATES



CERTIFICATES



**Certificate of appreciation by NAFFCO CEO
Eng. Khalid Al Khatib**



CERTIFICATES



**Certificate of appreciation by NAFFCO CEO
Eng. Khalid Al Khatib
NAFFCO at intersec 2024**



CERTIFICATES



CERTIFICATES



Certificate of appreciation by Director of Civil Defense During Al-Raedy Company's participation in Civil Defense Day





OUR MAJOR PROJECTS

OUR MAJOR PROJECTS



No.	PROJECT	SCOPE	REMARKS	DATE
1	Basra Investment Commission	Fire Alarm System	Supply and Installation	2023
2	R-Zero Project	Fire Alarm System & Fire Fighting System	Supply and Installation	2023
3	Kadhim Al-Batat Hospital	Fire Alarm System	Supply and Installation	2023
4	Kuwait Surgical Hospital	Fire Fighting System & FM200 System & Fire Extinguisher	Supply and Installation	2023
5	Al-Nabaa Al-Adheem Hospital	Fire Rated Doors	Supply and Installation	2023
6	Basrah University for Oil & Gas	Fire Fighting System	Supply and Installation	2023
7	General Electric Power Transmission Company - Southern Region	Fire Fighting System	Supply and Installation	2023
8	General Electric Power Transmission Company - Southern Region	Safety Suits	Supply	2023
9	College Of Science Project – Al-Zubair	Fire Fighting System	Supply and Installation	2023
10	North Basra Networks	Fire Extinguisher	Supply	2023
11	South Basra Networks	Fire Extinguisher	Supply	2023
12	South Basra Networks	Fire Fighting System	Supply	2023
13	South Basra Networks	Fire Alarm System	Supply	2023
14	South Basra Networks	Filling gas cylinders	Filling	2023
15	Ramadan Juice Building	Fire Alarm System & Fire Fighting System	Supply and Installation	2023

OUR MAJOR PROJECTS



No.	PROJECT	SCOPE	REMARKS	DATE
16	Mas Hall	Fire Alarm System	Supply and Installation	2023
17	Al-Sultan Sports Center	Fire Fighting System	Supply and Installation	2023
18	Al-Basra Al-Fayhaa Private Schools	Fire Fighting System	Supply and Installation	2023
19	College of Madeine Building	Fire Fighting System	Supply and Installation	2023
21	Bawabat Al-Noor Company	Fire Fighting System	Supply and Installation	2023
22	Darek Restaurant	Fire Fighting System	Supply and Installation	2023
23	Tamam Yogurt Factory	Fire Fighting System	Supply and Installation	2023
24	Heavy Engineering Equipment State Company	Foam Tank Chamber	Supply	2023
25	New Nuclear Medical Ward Project	FM200 Systems	Supply and Installation	2023
26	TAS	Supply coverall suite	Supply	2022
27	Ministry of Electricity	Fire Pumps and Cabinets	Supply and Installation	2022
28	Basra Oil Company	Landing Valve	Supply	2022
29	Basra Oil Company	Road Barrier	Supply	2022
30	The General Company for Petrochemical Industries	Fire Alarm System	Supply and Installation	2022

OUR MAJOR PROJECTS



No.	PROJECT	SCOPE	REMARKS	DATE
31	Espresso Coffee Shop	Fire Fighting System	Supply and Installation	2022
32	Science University	Fire Fighting System	Supply and Installation	2022
33	Hyundai CO. – South Oil CO	Fire Fighting pump	Supply and installation	2022
34	Cancer Hospital	Fire Fighting equipment	Supply	2022
35	Basra University Hospital	Fire Fighting System	installation Only	2021
36	Al-Hartha Hospital	Fire Fighting System	Supply and installation	2021
37	Albatat Hospital	Fire Alarm System	Supply and installation	2021
38	Collage of Medicine	Fire Alarm System	Supply and installation	2021
39	Toke Alrian CO	Fire Fighting equipment	Supply	2021
40	Toyota CO	Fire Fighting System	Supply and installation	2021
41	Al-Farahidi Hospital	Fire Doors	Supply and installation	2021
42	Al-Farahidi University	Fire extinguishers	Maintenance	2021
43	Taiez Co	Fire Alarm System and Fire equipment	Supply and installation	2021
44	South Oil Co	breathing ventilator	Supply	2021

OUR MAJOR PROJECTS



No.	PROJECT	SCOPE	REMARKS	DATE
45	Prim Power Co	Fire Fighting equipment	Supply	2021
46	Al-Konoz University	Fire Fighting equipment	Supply	2021
47	Samsung Work Shop	Fire Fighting System	Supply and Instillation	2021
48	KAR CO.	Safety equipment	Supply	2021
49	Al-Bara Oil Co.	Safety equipment	Supply	2021
50	Medical Building	Fire Fighting System	Supply and Instillation	2021
51	Al-Bara Gas Co.	Fire hose cabinets	Supply	2021
52	Prime Metro Power	Firefighting Equipment	Supply	2021
53	Al-Isawy Shop Center	Fire Fighting System	Supply and Instillation	2020
54	Al-Maaqal University	Fire Fighting System	Supply and Instillation	2020
55	Dar AL-Shifaa Investment Hospital	Firefighting Equipment	Supply and Instillation	2020
56	Al-Kunooze University Colloge	Firefighting Equipment	Supply and Instillation	2020
57	AL-Nokbah Laboratory building	Fire Fighting System	Supply and Instillation	2020
58	Lafarge Co./ Karbal	Firefighting Equipment	Supply	2020
59	Al-Sanii Building	Fire Fighting System	Supply and Instillation	2020

OUR MAJOR PROJECTS



No.	PROJECT	SCOPE	REMARKS	DATE
60	Basra Oil Co.	Foam Bladder Tank	Supply	2020
61	KAR Co.	Safety equipment	Supply	2020
62	Oil Project Co.	Safety and Firefighting equipment	Supply	2020
63	Basra Mass Co.	Fire Alarm Basra Cinema	Supply and installation	2020
64	Horizon hotel	Wet Chemical fire-fighting System	Supply and installation	2019
65	Albahaa CO. for printing	Fire pump 5 Bar	Supply and installation	2019
66	State Company For Iron and Steel	CO2 firefighting System	Supply and installation	2019
67	Basra Mass Co.	CO2 firefighting System	Supply and installation	2019
68	Iraqi Drilling Co.	3 fire pumps	Supply & Maintain	2019
69	Karbala Cancer Hospital	Safety Equipment	Supply Only	2019
70	Kuwait Energy Co.	FM200 Firefighting System	Supply and Maintain	2019
71	Iraqi Drilling Co.	Safety Equipment	Supply Only	2019
72	Basra Oil Company	Firefighting System	Supply	2019
73	Iraqi Drilling Co.	6 fire pumps	Supply Only	2019
74	Basra Mass Co.	Fire Alarm Basra Cinema	Supply and installation	2019
75	Imam Hussein Hospital	Fire Pump 350GPM	Supply Only	2019

OUR MAJOR PROJECTS



No.	PROJECT	SCOPE	REMARKS	DATE
76	Black Sea Company	IG Firefighting system for The Site	Supply and installation	2019
77	Basra Mass Co.	Kitchen hood systems	Supply and installation	2018
78	Baghdad Co.	Fire alarm system	Supply and installation	2018
79	NPS Company	Firefighting system	Supply and installation	2018
80	Iraqi Drilling Co.	Supply two fire pumps	Supply Only	2018
81	Iraqi Drilling Co.	Supply two fire pumps	Supply and Installation	2018
82	Ministry of Defense	Supply Ambulance	Supply	2018
83	NPS Company	Firefighting and fire alarm systems	Supply and installation	2017
84	Basra Stores	Firefighting system	Supply and installation	2017
85	Lafarge Company	Safety and protection equipment	Supply	2017
86	Basra Mass Co.	Firefighting and fire alarm systems for Horazone Hotel	Supply and installation	2017
87	Basra Center Mall 2	Fire alarm system	Supply and installation	2017
88	Basra Bowling Center	Fire alarm system	Supply and installation	2017
89	Qiewan Co. -Sulymaneya	Firefighting and fire alarm systems for Qiewan Tower	Commis-sioning and Testing	2017

OUR MAJOR PROJECTS



No.	PROJECT	SCOPE	REMARKS	DATE
90	Arbil Airport	Kitchen Hood Systems ⁷	Installation and Testing	2016
91	Kuwait Energy Co.	FM200 Firefighting System	Supply and installation	2016
92	Basra Times Sq. Mall	FM200 Firefighting System	Supply and installation	2016
93	Petronas Co.	Fire Fighting Vehicle	Supply one vehicle	2016
94	Petrojet Co.	FM 200 firefighting system	Supply and installation 2 unites	2016
95	Egypt Sun Co.	Firefighting pump	Supply and installation	2016
96	Basra Mass Co.	Fire alarm systems 2 unites	Supply and installation	2016
97	Basra Center Mall	Fire alarm systems 4 unites	Supply and installation	2016
98	Basra Gas Co.	Hazmit & Training Vehicles	Supply 4 Vehicles	2015
99	Britam Co.	Firefighting and fire alarm systems	Supply and installation	2015
100	Shell Co.	Safety and protection equipment	Supply	2015
101	South oil Company/ Ministry of oil	Exhaust Fan, Fire Extinguisher	Supply	9/2015
102	Basra Police Department	Design and Supply of FM-200 System	Supply and installation	5/2015

OUR MAJOR PROJECTS



No.	PROJECT	SCOPE	REMARKS	DATE
103	South oil Company/ Ministry of oil	400 lit Foam, Cabinet	Supply	3/2014
104	State Company for Ports of Iraq	20 Firefighting Vehicle	Supply	1/2014
105	Missan Oil Company - Missan	H2S Detector	Supply	7/2014
106	Korak Company - Wasit	Firefighting Equip- ment	Supply	3/2014
107	Iraqi Drilling Company - Missan	Powder Fire Extin- guisher	Supply	1/2014
108	EMC	Fire hose, Cabinets, Fire Extinguisher , Safety Equ.	Supply	2/2014
109	Nawaeer Al Khair	Hydrant Cabinets	Supply	2/2014
110	BAKER HUGHES	Fire Hydrant	Supply	1/2014
111	SKA	Design and Supply Fire pump system	Supply and installation	9/2014
112	Basra Mas/ Marine	Fire alarm system	Supply and installation	9/2014
113	Basra Mas/ Marine Building	Fire alarm system	Supply and installation	7/2014
114	SCHLUMBERGER	Fire Extinguisher	Supply	12/2013
115	Bazerkan power sta- tion - Missan	Design and Supply of FM-200 System	Supply and installation	11/2013
116	Diesel power station – North Missan	Firefighting Equip- ment	Supply and installation	9/2013
117	kahlaa power Station – Missan	H2S Detector	Supply	8/2013

OUR MAJOR PROJECTS



No.	PROJECT	SCOPE	REMARKS	DATE
118	DhiQar post office - DhiQar	Supply Fire Alarm System	Supply and installation	8/2013
119	Missan Oil Company - Missan	Firefighting Equipment	Supply	7/2013
120	Missan Oil Company - Missan	Multi H2S Detector, H2S	Supply	6/2013
121	Missan Oil Company - Missan	Firefighting equipment (Dry powder, CO2, Foam)	Supply	5/2013
122	Alraidh Company –kerbala / Najaf	Pumps 9 bar, Fire-fighting Materials	Supply	4/2013
123	Alraidh Company –kerbala / Najaf	Pumps 5 bar, Fire-fighting Materials	Supply	1/2013
124	Ministry of Health	620 Ambulance Car	Supply	10/2013
125	Kor Alzober Power	Design and supply fire alarm	Supply and installation	9/2013
126	PETROCHINA	Fire Extinguisher (Foam, Powder, CO2)	Supply	4/2013
127	LUKOIL	Firefighting Vehicle	Supply	1/2013
128	BAKER HUGHES	Design and Supply Fire Pump system,	Supply and installation	12/2013
129	Eni Saipem	Fire Extinguisher (Dry Powder, Foam)	Supply	12/2013
130	Gulf Company	Design and supply fire alarm system, Fire-fighting	Supply and installation	4/2013

OUR MAJOR PROJECTS



No.	PROJECT	SCOPE	REMARKS	DATE
131	Alfihai Company	Design and Supply Fire pump system and Fire alarm system	Supply and installation	8/2013
132	Basra Governorate Council	Design and Supply Fire pump system and Fire alarm system	Supply and installation	5/2013
133	The Directorate production of electrical energy	Design and Supply of FM-200 System	Supply and installation	4/2013
134	Alhayanih storage	Design and Supply Fire pump system	Supply and installation	10/2012
135	Alhayanih storage	Design and supply fire alarm system	Supply and installation	5/2012
136	Iraqi Drilling Company	Fire Pump	Supply	4/2012
137	Iraqi Drilling Company - Missan	CO2 and Powder Fire Extinguisher	Supply	12/2012
138	Wasit Sector - Wasit	Firefighting Pump equipment (Fire monitor, Wet hydrant, Get valve)	Supply	11/2012
139	Bazerkan power station - Missan	Firefighting equipment (Dry powder, CO2, Foam)	Supply	8/2012
140	Bazerkan power station - Missan	Safety equipment	Supply	7/2012
141	State Company for Fertilizer	Safety equipment	Supply	10/2011
142	South oil Company/ Ministry of oil	Fire Extinguisher	supply	6/2011

OUR MAJOR PROJECTS



No.	PROJECT	SCOPE	REMARKS	DATE
143	Oil Products Distribution Company	Artificial ventilator, Ventilator, H2S	Supply	3/2011
144	Kor Alzober Power station	Design and supply fire alarm system	Supply and installation	1/2011
145	South oil Company/ Ministry of oil	Fire Hydrant	supply	3/2010
146	Iraqi Drilling Company - DhiQar	Firefighting equipment (Dry powder, Co2, Foam)	Supply	8/2010
147	State Company for Ports of Iraq	6 Firefighting Truck and 4 Firefighting Water Tank	Supply	10/2009
148	Ministry of Industry	Firefighting Pipe Line	Supply and installation	1989
146				



شركة
الرائدي الهندسية
للسلامة ومكافحة الحرائق

OUR MAJOR PROJECTS



Supply and Installation Fire Fighting System of «Grand Market» Building



OUR MAJOR PROJECTS



Installation Fire Fighting System of Al-Basra University Hospital



OUR MAJOR PROJECTS



Installation Fire Fighting Pump of HYUNDAI Co. / South Refineries Co. / ALSHUIBA



OUR MAJOR PROJECTS



Supply & Installation Fire Fighting System and fire alarm system In Al-ABBAS Project (R Zero)



OUR MAJOR PROJECTS



Supply and Installation Fire Fighting System in Kuwait Surgical Hospital



OUR MAJOR PROJECTS



Supply and Installation FM200 Systems & Fire Rated Doors in New Nuclear Medical Ward Project



OUR MAJOR PROJECTS



Supply and Installation Fire Fighting Systems in College of Science Project Al-Zubair



OUR MAJOR PROJECTS



Supply and Installation Fire Rated Doors in Al-Nabaa Al-Adheem Hospital



Supply & Installation Fire Alarm System in Basra Investment Commission Building



OUR MAJOR PROJECTS



Supply & Installation Fire Fighting System in Darek Restaurant



Supply & Installation Fire Fighting System In Al-Sultan Sports Center



OUR MAJOR PROJECTS



Supply & Installation Fire Alarm System In Kadhim Al-Batat Hospital



Supply & Installation Fire Fighting System In Horizon Hotel



OUR MAJOR PROJECTS



Supply Fire Fighting Equipment In Al-Konoz University



Supply & Installation Fire Fighting System In Al-Basra Al-Fayhaa Private Schools



OUR MAJOR PROJECTS



Supply & Installation Fire Extinguisher Automatic in MC Smoked restaurant

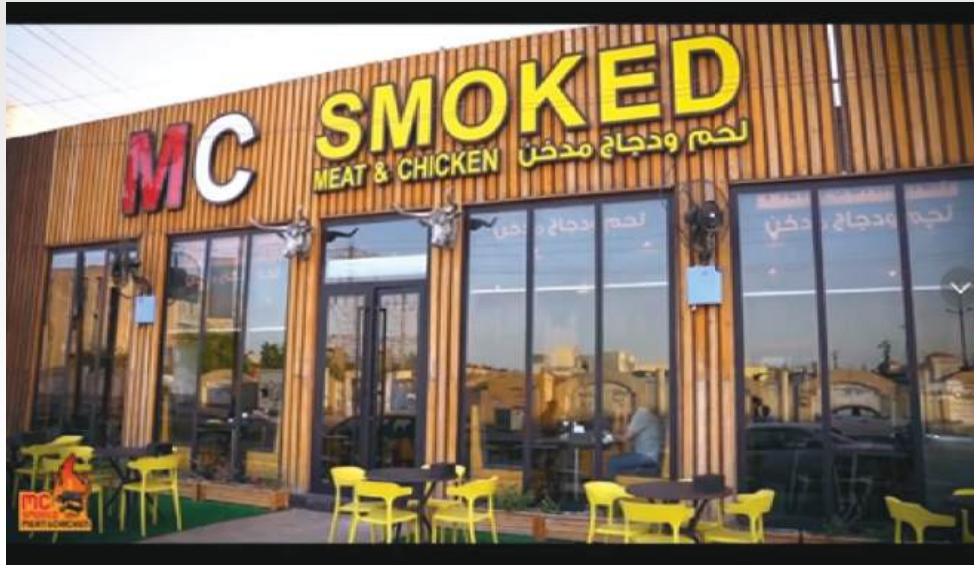

Supply and installation Fire Fighting system In the General Directorate of Production Electrical Power in Basra



OUR MAJOR PROJECTS



Supply & Installation Fire Rated Doors in Al-Faraheedi Hospital



OUR MAJOR PROJECTS



Supply and installation Fire Fighting system In the General Directorate of Production Electrical Power in Basra



OUR MAJOR PROJECTS



Supply & Installation Fire Fighting System in Qasr Al-Sultan Hotel



Supply & Installation Fire Alarm system in Basra Mas Buildings



OUR MAJOR PROJECTS



**Supply & Maintenance Fire Extinguisher
in Al-Tazaj Iraqi CO.**



**Supply & Maintenance Fire Extinguisher
in State CO. for Maritime Transport**



OUR MAJOR PROJECTS



Supply & Installation Fire Fighting system in Al-Majedi Building - Basra



Supply & Installation Fire Fighting system in IstanBlue Mall - Basra



OUR MAJOR PROJECTS



Supply & Maintenance Fire Extinguisher in Al-Lamiy Mall



Supply & Installation Cabinets & Fire Fighting System in Al-Lamiy Mall



OUR MAJOR PROJECTS



Supply & Installation Fire Fighting System in Al-Narjis CO. Building



OUR MAJOR PROJECTS



Supply & Installation Fire Fighting System in Al-Hartha Hospital



OUR MAJOR PROJECTS



Supply & Installation Fire Fighting System in ESPRESSO LAB



**Your Safety
Is Our Mission**



شركة
الرائدي الهندسية
للسلامة ومكافحة الحرائق

OUR MAJOR PROJECTS



Supply & Installation Fire Fighting System in Toyota Storage



OUR MAJOR PROJECTS



Presentation For NPS safety and firefighting system



Our participation in Basra International Expo for Oil and Gas



OUR MAJOR PROJECTS



Lecture about new Firefighting Systems



Signed the Contract with the TECO. To Installation the firefighting System of AL-Basra University Hospital



OUR MAJOR PROJECTS



Supply 20 Firefighting Vehicles for Iraqi Port



Supply 8 Mobile Clinics for Ministry of Health



OUR MAJOR PROJECTS



Supply 620 Ambulances for Ministry of Health



Supply Two High Tension Electrical cable maintain Vehicles for Ministry of Electric



OUR MAJOR PROJECTS



Supply Fire Extinguisher In Al-Kadhimy Building



Supply and Installation Firefighting Pump for Basra Government Building



OUR MAJOR PROJECTS



Supply and Installation Firefighting Pump for KAS Co.



Supply and Installation Firefighting Pump for KPS



OUR MAJOR PROJECTS



Supply and Installation Firefighting Pump for EMC



Supply and Installation Firefighting Equipment's of Dar AL-Shifaa Investment Hospital



OUR MAJOR PROJECTS



Supply and Installation 4 Fire fighting Pumps for Al-Maaqal University



Supply 2 Foam Tank Chamber for Basra Oil Company



OUR MAJOR PROJECTS



Preparation and installation An integrated fire-fighting system in Asir Time Building





Products

Products

Fire Fighting Equipment



Fire extinguishers



Fire Hose Reel

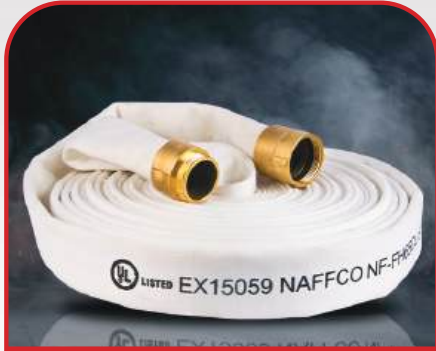

Fire Hoses



Fire Cabinets



Valves and Riser Equipment



Fire Hydrants



Fire blankets

Products

Gas Based Suppression System



Co2 System



Fm200 System



Aerosol System



Kitchenhood System

Products

Fire Pumps & Controllers



Pump House Unit



Fire Pump Products



Industrial Packaged Pumpset



Advanced Fire Pump Solutions

Foam Equipment & Concentrates



Foam Concentrate



Foam Equipments

Products

Fire Doors



Fire & Smoke Curtain



Glazing System

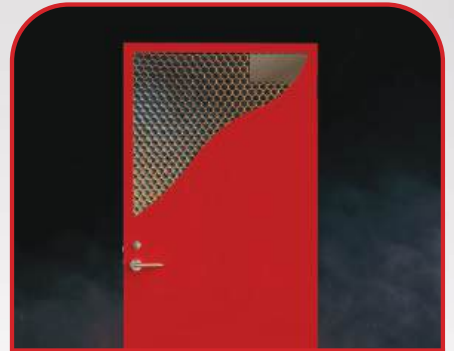

Fire Rated Doors



Security Doors



Rolling Shutters



Blast Doors

Products



Trucks & Vehicles



Fire Trucks & Special Vehicles



Ambulances & Special Vehicles



Mobile Clinics



Car wash insulation

Products

Smoke Management System



Natural Smoke Vents



Fire Ducts & Dampers



Fans



Starter Panels



Smoke Control Stations



Fire & Smoke Curtains



Solutions



Smoke, CO & Nox Detectors



Electrostatic Precipitator

Products



Safety Signs



Low Location Lighting



Mandatory Signs



Prohibition Signs



Escape Route Signs

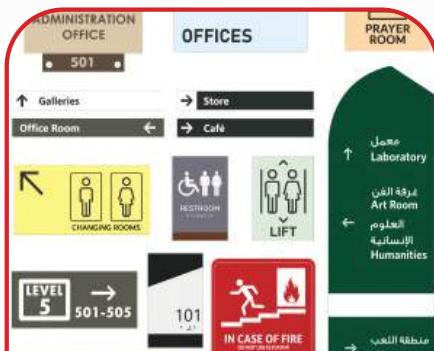

Building Signs



Traffic Signs



Evacuation Plan



Health and Safety - Warning Signs



Fire Fighting Equipment Signs

Products



Safety & Rescue



Industrial
Equipment



Firefighter
Equipment



شركة
الرائدي الهندسية
للسلامة ومكافحة الحرائق

**Safety
First**

Products



NFM 40/4-SC Light Duty Firefighting Vehicle

CHASSIS
MAN TGL 12180, 4x2; Single Cabin, Manual Transmission,
180 HP, 11,900 KG GVW

BODY STRUCTURE
Made using aluminum profiles 6061 T6, fastened to a strong base structure made of stainless steel tubing

STORAGE LOCKERS
Five (5) storage lockers, two on the R/H side and two on the L/H side and one on the rear of the vehicle closed by light alloy roller shutters.

WATER & FOAM TANKS
4,000/400 Liters made of Polypropylene with life time warranty

FIRE PUMP
PTO Driven, Single stage, centrifugal type normal pressure pump,
2,000 LPM at 10 bar and 3 meter suction lift.

FOAM SYSTEM
Around-the-Pump-Foam Proportioning System 0 - 6 %, Manual adjustable

MONITOR
Water / Foam Monitor with jet/fog pattern, with adjustable output from
800 LPM to 1,600 LPM and throw range up to 50 meters.

HOSE REEL
Manual Rewind hose reel fitted with rubber hose of 1.25" x 30m fitted
with pistol type nozzle for jet and fog patterns.

ACCESSORIES
Wide range of fire fighting accessories and equipments including
hoses, nozzle, SCBA Sets, Generator and personal fire protection sets.



Notes:
NAFFCO reserve the right to introduce minor changes to improve operational and performance related aspects of the vehicle and if also necessary to supply equivalent equipment/components if they should become unavailable or obsolete.

Products



Products



Products



CHASSIS

- MB Sprinter Panel Van
- 4x2, Diesel Engine
- GVWR : 4100 kgs
- Automatic transmission

FLOOR

- Isolated with polyurethane foam material
- Heavy-duty vinyl anti-slip
- Anti-static and liquid-proof

INTERIOR FINISHING

- GRP white finish
- Sliding window provided

INSULATION

- Enhance the cabinet environment
- Noise and AC sound proof

MEDICAL STORAGE CABINETS

- Upper Cabinets
- Oxygen Cabinets
- Vertical wall shelves

ATTENDANT SEAT

- One EMSP facing backward
- Two on the RHS of the stretcher

MEDICAL EQUIPMENT

- Oxygen system
- Diffribulator
- Portable suction
- Emergency bag
- KED Splint

ELECTRICAL SYSTEM

- Audible Warning/PA system
- Light Bar
- Perimeter Emergency Warning Lights
- Scene Lights
- LED Lights
- Air-conditioning system
- Ventilation Fans

** For other Medical Equipment as per Customer Requirements.*

- Traction Splint
- Spine board
- Portable Oxygen Cylinder
- Mini stretcher
- Hand sanitizer

- 12V DC power Sockets
- 220V AC power Sockets
- Inverter Charger
- Control Panel
- One drawer fridge
- Electrical operated side step

Products



TYPE I AMBULANCE GMC 4x4



01 CHASSIS

- GMC Sierra
- 4x4, Petrol Engine
- GVWR : 6350 kgs
- Automatic transmission

02 BODY STRUCTURE

Super structure aluminum tubes.

03 FLOOR

- Isolated with polyurethane foam material
- Heavy-duty vinyl anti-slip
- Anti-static and liquid-proof

04 CEILING

- GRP material
- Roof lights
- Two Intravenous (IV) feeding
- Overhead handrail

05 LHS MEDICAL CABINET

- GRP finish
- Large compartment with flexi glass sliding door
- Large action area for monitoring equipment
- Easy access Electrical Control Panel

06 ALS CABINET

- GRP finish
- Storage compartment

07 EXTERNAL CABINETS (Storage Areas for)

- Oxygen Cylinder
- Spare Wheel
- Scoop Stretcher
- Electrical

08 EMSP SEATS

- Adjustable Arm rest
- Sliding and rotating features
- With 3-point seat belt

09 SQUAD BENCH

- Foam padding and upholstery cover
- Two point seat belt
- Storage underneath
- Can accommodate up to 3 persons

10 INTRA-VENOUS HOLDERS

- Two recessed dual IV hangers
- NFPA 1917 Standard

11 STEPS

- Foldable Rear steps
- Electrical operated side step

12 CENTRAL OXYGEN SYSTEM

- Hospital-type M-size Cylinder
- Two Self-Standing Outlets

13 REAR AIR CONDITIONING SYSTEM

- Separate A/C system
- Automatic Digital Climate Control

14 ELECTRICAL SYSTEM

- Warning Lights
- LED Light Bar
- PA System
- Internal lights
- Loading light
- Scene lights
- Map reading lights
- Shoreline
- Inverter
- Intercom
- Reverse alarm system
- Rear view camera system
- 12V DC Power Socket with Plug
- 230 ± 10 V AC Power Socket



** For other Medical Equipment as per Customer Requirements.*

www.naffco.com



Products



 **FIRE SUPPRESSION SYSTEMS** 



THE NEW IMPULSE VALVES TECHNOLOGY

FM-200[®]
CLEAN AGENT
FIRE SUPPRESSION SYSTEM

PROTECTING WHAT MATTERS MOST

EFFICIENT **CLEAN** **PROVEN**



Products



مؤسسة محمد بن راشد آل مكتوم للأمن
MOHAMMED BIN RASHID AL MACTOUM FOUNDATION FOR SAFETY
تأسست 2008
مقرها 336
صناعة 310
11114

FIRE PUMPS



UL LISTED
FM APPROVED

THE FIRE PROTECTION SPECIALISTS

Products



NAFFCO FIRE PUMP SET NPS SERIES

This package consists of one main pump coupled to electric motor, one stand by pump coupled to diesel engine, jockey pump, pressure vessel, controller(s) for manual or automatic operation of the system and standard accessories on base frame(s). The electric pump shall be End Suction or Single Stage Horizontal split case or Horizontal multi stage centrifugal depending on the System capacity and head requirements. Electric motor is squirrel cage induction type and foot mounted suitable for 3 phases, with required horse power rating. The diesel engine is fixed on the base with anti-vibration rubber pads and the pump is directly coupled to a diesel engine through flexible coupling. According to the power output of the engine the electrical system can be either 12V or 24V DC.

The diesel engine consists of alternator, starter motor, fuel system, lubricating system, exhaust system, etc. The jockey pump is vertically mounted multi stage pump close coupled to TEFC, 3 phase motor. The controller shall be either common or individual (Electric, Diesel & Jockey) fabricated from mild steel and electrostatic powder coated to grey color. The enclosure is IP 54 rated and having all the required controls complying with the applicable standard (Local Jurisdiction Authority requirements). The standard Fire Pump set will be complete with pressure switches, pressure gauge, suction & discharge manifolds with gate valves, non-return valves, flexible connectors and battery for diesel engine. Pumps are mounted on strong individual or common base frame(s) of mild steel and painted red. This Fire Pump set is designed to be installed with the following Fire Protection Systems.

- Hose Reel System • Combined System.
- Deluge System (with modifications) • Stand Pipe System.
- Water Spray System • Sprinkler System.

Range for fire pump set model NPS series

Flow Rate	Pressure
300 - 2500 US GPM	5 - 18 Bar

Note: Higher ranges are available upon request



DESCRIPTION

1.	ELECTRIC PUMP SET
2.	DIESEL PUMP SET
3.	JOCKEY PUMP
4.	GATE VALVE
5.	FLEXIBLE COUPLING
6.	NON RETURN VALVE
7.	BALL VALVE
8.	SUCTION MANIFOLD
9.	DELIVERY MANIFOLD
10.	PRESSURE GAUGE
11.	PRESSURE SWITCH
12.	PRESSURE VESSEL
13.	UNION

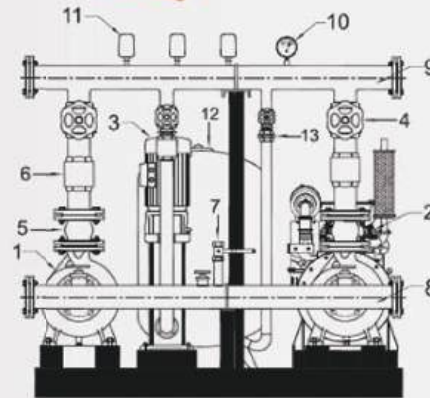

FRONT VIEW

naffco.com | 5

Products



SHIELD
Trusted Worldwide

Fire Detection & Evacuation System

www.shieldglobal.com

Products

ABC DRY POWDER MOBILE FIRE EXTINGUISHER

PRODUCT DESCRIPTION

NAFFCO Mobile stored pressure ABC Dry powder extinguishers are characterized by their high performance and simple method of operation. The ABC Dry powder Mobile type extinguisher contains high performance powder and thus has achieved highest fire rating.

They are suitable for multipurpose application of fires involving free burning materials, flammable liquids, flammable gases and electrical equipment.

Effective for Class A, B, C & Electrical fires.



FEATURES

- The fire extinguishers are designed to comply all the specification requirements of BS EN 1866-1.
- Kitemark & LPCB approved for different capacity extinguishers.
- Highest fire rating due to high performance ABC powder.
- Ready for instant use and simple to operate.
- Fully controlled and easy operation by rust free brass valve.
- Cart and cylinder are made of rugged steel and welded to meet extreme use conditions.
- Easily transportable & Field rechargeable.
- Highly visible pressure-indicating gauge.
- Externally coated by Electrostatic powder painting after shot blasting ensures maximum corrosion resistance.
- Brass nickel plated head valve with simple lever operation.

MODEL NUMBER	NTP25	NTP50	NTP100
Extinguisher capacity	25 Kg	50 Kg	100 Kg
Fire Rating	IIB	IVB	IVB
Working Pressure	18 Bar	18 Bar	18 Bar
Maximum Working Pressure	22 Bar	22 Bar	22 Bar
Test Pressure	32 Bar	32 Bar	32 Bar
Total Height & Width	990 x 500 mm	1080 x 550 mm	1050 x 650 mm
Total Weight	Approx. 63 Kg	Approx. 100 Kg	Approx. 172 Kg
Range of Discharge	7-9m	7-9m	8-9m
Duration of Discharge	25-30 Sec	47-55 Sec	85-90 Sec
Operating Temperature	-20°C to +60°C	-20°C to +60°C	-20°C to +60°C
Propellant	Nitrogen	Nitrogen	Nitrogen
Hose size & Length	16mm x 5 mtr	16mm x 5 mtr	16mm x 7 Mtr
Cylinder Material	Hot rolled Annealed steel plate		

Products



CABINET FOR FIRE HOSE REEL, FIRE EQUIPMENT AND BREECHING INLET

CABINETS

PRODUCT DESCRIPTION

NAFFCO cabinets are designed to accommodate fire hose reel, fire fighting equipment and breaching inlet. Fire hose reel cabinets are manufactured to comply with BSEN 671-1

standard and breaching inlet cabinets are manufactured to comply to BS 5041 -5 standard.

FEATURES

- LPCB Certified.
- Cabinet material made of Electro Galvanized sheet or Stainless Steel Sheet (Full stainless steel brush or mirror finish).
- Locking of cabinet is either key operated or round handle cam latch.
- Cabinets are available either in surface mounted or recessed mounted type.
- Cabinet door shall be solid door.
- Breaching inlet cabinets are available in horizontal or vertical version.



Products



DRY PILLAR FIRE HYDRANTS



FEATURES

- LPCB approved
- NAFFCO Fire Hydrants are manufactured to comply BS EN 14384: 2005, BS 1074-1, BS 1074-2 & BS 1074-6 Standards.
- Dry barrel design eliminates damage to the hydrant caused by freezing of the upper part.
- NAFFCO Fire Hydrants are designed for high performance and easy to install, maintain and repair.
- Excellent and proven flow characteristics.
- 2 x 1/2" straight through landing valve with female instantaneous outlet to BS 336:2010.
- Body material made of spheroidal graphite cast iron (Ductile Iron) to BS 1563:2011.
- 2 x 1/2" Female Instantaneous quick coupling adaptor to BS 336:2010.
- 1 x 4" Male/Female BSRT pumper to BS 336:2010.
- Aluminum Hood / GRP cover is provided for protection and misusing.
- Operation threads are corrosion protected and for easy operation.
- NAFFCO Fire Hydrants are high Pressure rating to 16 Bar.
- Drain starts automatically when hydrant is closed.
- Internal epoxy paint system gives high corrosion protection to hydrants.
- Hydrant protective covers with handle for easy handling.

Products



FIRE RATED DOORS

NAFFCO manufactures ANSI and BS standard fire rated doors. Fire rating does not depend on property of construction, but on the performance of complete elements of structure, which is composed of a number of materials. NAFFCO fire rated doors are designed to get optimal performance from a number of materials combined to perform for high degree of fire protection.

The design of NAFFCO fire rated doors evolved from actual testing as per NFPA and BSEN standards, which deal with methods of determination of resistance to fire of non load bearing element construction.

NAFFCO fire rated doors satisfy these criteria for the required period. These doors also satisfy the criteria of insulation where the mean and minimum temperature is required to be below specific figures as per standards.

Design and construction of NAFFCO fire rated door assemblies are in accordance with NFPA 80, UL10B, UL 10C, BS 476 Part 22 and other international standards.

NAFFCO UL classified doors are tested and certified with 2 hours fire rating. BS standard doors maintains certification till 2 hours for Honeycomb door and 3 hours for glazed door.



NAFFCO FIRE CERTIFIED HARDWARE

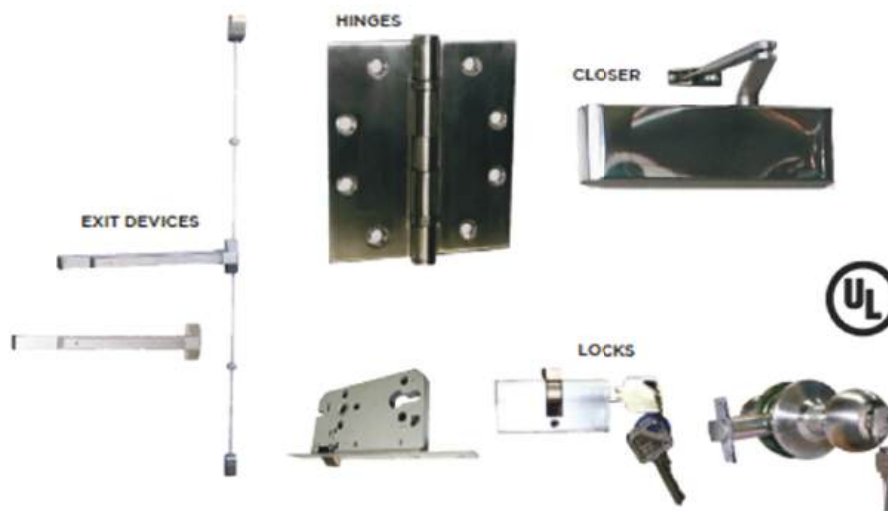

May it be fire rated, normal, classic, traditional or modern, we have a vast collection of hardware to suit your design needs. From lock case, lever handles, cylinders and deadlocks, we have it all in different finishes like satin finish, gold finish, bronze finish and silver finish.

You will never go wrong with the selection of your preferred hardware since NAFFCO offers only the finest quality brands.

Products



CO₂ PORTABLE FIRE EXTINGUISHERS (UL LISTED)

PRODUCT DESCRIPTION

NAFFCO CO₂ gas extinguishers are characterized by their high performance for fires including items at risk for electrical shorts like computer, office equipment and

generators etc. Co₂ is non conductive, clean and safe, ensuring minimal damage to electrical equipment and furnishings. Suitable for Class B fire risks.



FEATURES

• Carbon Dioxide is the trusted nonconductive cleaning agent and is most effective for dealing with electronic equipment fires. CO₂ is suitable for use on Class B and Class C fires.

facilities, auto dealerships, vehicle/aircraft/marine service centers, and manufacturing processes such as painting, dipping, and coating.

• TYPICAL USES: For protecting sensitive electronic equipment in offices, classrooms, parking garages, and hotel/motel assembly halls and guest areas. For protecting sensitive electronic equipment in businesses such as retail stores, light manufacturing facilities, research

• Not suitable for use on fires involving cooking oil and grease. Recommended for use on sensitive electronic equipment.

MODEL NUMBER	N 05LC	N 10LC	N 15LC	N 20LC
Agent Capacity	5 lb. (2.27 Kg)	10 lb. (4.54 Kg)	15 lb. (6.8 Kg)	20 lb. (9.07 Kg)
UL Rating	5-B:C	10-B:C	10-B:C	10-B:C
Discharge Time	9 Sec	9 Sec	15 Sec	20 Sec
Range (FT/M)	4-8 / 1.2-2.4	4-8 / 1.2-2.4	4-8 / 1.2-2.4	4-8 / 1.2-2.4
Bracket	Wall	Wall	Wall	Wall
Ship Weight	13.75 lb. (6.3 Kg)	27.75 lb. (12.6 Kg)	37.75 lb. (17.1 Kg)	49 lb. (22.2 Kg)
Unit Height	17.375 in (44.1 cm)	19.75 in (50.2 cm)	26.375 in (67 cm)	26.875 in (68.2 cm)
Unit Width	8.25 in (21 cm)	12 in (30.5 cm)	12 in (30.5 cm)	13 in (33 cm)
Unit Diameter	5.25 in (13.3 cm)	6.89 in (17.5 cm)	6.89 in (17.5 cm)	8 in (20.3 cm)



Remember!

**Your Safety Comes First
When in Doubt, Leave
the Fire Fighting to the
Professionals**



ALRAEDY
ENGINEERING COMPANY

Distinguished in the world of safety and firefighting

This sector in Iraq is characterized by the recent interest in it. Before 2003, it was an unimportant matter and the regulatory authorities did not think about it. The reliance was on government civil defense only. This philosophy changed after 2003, as international companies demanded attention to high-security safety procedures, and the markets lacked For this required equipment,

Al-Raedi Engineering Company emerged as a distinguished leader in this type of work, and concluded agreements with NAFFCO, an international company based in Dubai, which is one of the finest and best companies operating in the firefighting sector. We have achieved wonderful achievements throughout 16 years of excellence.



Our Website



Our Instagram